

# TH

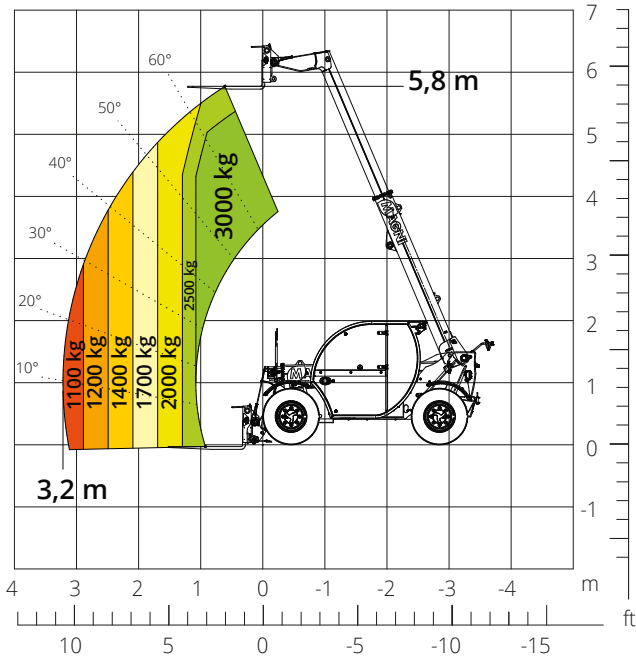

# 3.6

PRELIMINARY



Load chart on tyres



-   
**CONSTRUCTION**
-   
**LOGISTICS**
-   
**MINING**
-   
**EVENTS AND FILM**

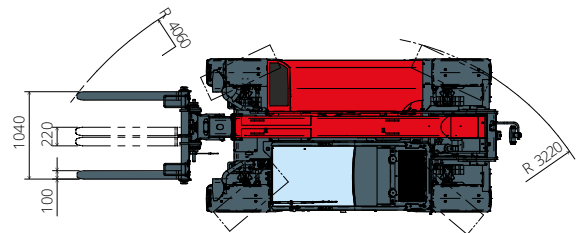
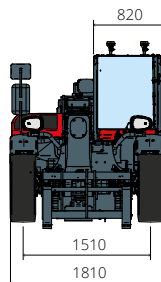
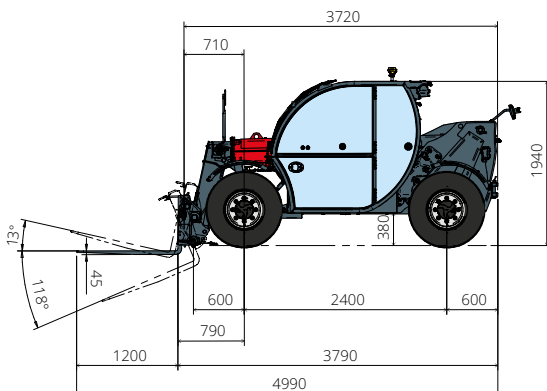

<b>Machine model</b>	Telescopic handler	TH 3.6	
	Maximum lifting capacity	3,000 kg	
	Maximum lifting height	5.80 m	
	Maximum reach	3.20 m	
<b>Stabilisers</b>	Type	-	
<b>Engine</b>	Model	<b>Deutz TCD 2,9 L4 EDG Stage IIIA</b>	<b>Deutz TCD 2,9 L4 Stage V</b>
	Rated power	55.4 kW (75.3 hp) at 2,600 rpm	
	Maximum torque	260 Nm at 1,600 rpm	
	Displacement	2.9 l	
	Cylinders	4 in line	
	Engine configuration	Turbocharged direct injection diesel	
	Cooling system	Water	
<b>Transmission</b>	Type	Hydrostatic	
	Maximum pressure	500 bar	
	Gear box	Direct drive 2 speed	
<b>Axles and brakes</b>	Type	Axles with planetary gearboxes	
	Front axle	Steering	
	Rear axle	Free oscillation	
	No. of driving/steering wheels	4WD - 4WS	
	Steering mode	Frontal/Concentric/Crab	
	Service brake	Wet multi-disk on front axle	
	Parking brake	Hydraulic with negative action on front axle	
<b>Performance</b>	Tyres dimensions	12.0/75 R18	
	Max. travel speed	35 km/h	
	Maximum mass towable on hook	3,100 kg	
	Gradeability	51%	
<b>Weights</b>	Turning radius (end of forks)	4,060 mm	
	Total unladen*	4,850 kg	
	Front axle unladen (boom retracted and lowered)*	2,000 kg	
	Rear axle unladen (boom retracted and lowered)*	2,850 kg	
<b>Tank and system capacities</b>	Fuel tank	65 l	
	AdBlue	-	
	Hydraulic oil tank	85 l	
	Engine oil tank	9 l	
<b>Hydraulic circuit for movements</b>	Cooling liquid	15 l	
	Circuit type	Gear pump	
	Service pump	Fixed displacement	
	Max. hydraulic flow rate	87 l/min	
	Max. boom head flow rate	75 l/min	
	Max. operating system pressure	255 bar	
<b>Standard met</b>	Controls for boom movements	Electro-proportional valve	
	Movements control	1 joystick with integrated manoeuvre enable	
		2006/42/EC: EU Machinery Directive 2016/1628: EU Regulation on the emissions of stage V engines EN 1459-X: Relating to standards on the safety requirements for variable reach machines EN 280/EN 280-1/EN 280-2: standards relating to mobile elevating work platforms (if available) ROPS/FOPS: relating to the standards for protective structures	

The data given in this brochure are provided for information purposes and are subject to change without prior notice. All images are purely guideline and might not give an exact representation of the product.

\*the stated weight refers to the vehicle unladen with standard equipment and may vary depending on the chosen configuration.